

Diesel Generator Set

K50 Series

1440kWe, 1800 kVA

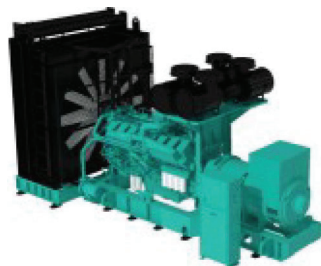

Reliable and Durable

Cummins® 'K50 series' diesel engine with strong regrindable crankshaft, high strength connecting rod, low pressure fuel lines, ESTC (Step Timing Controls) injectors and high volume coolant system make 'K50 series' generating sets, more reliable and durable. Engines have clocked millions of hours operating in some of the world's most demanding conditions. Current engines are regularly upgraded with new technologies for better performance and economy. The ultimate proof of superior performance and reliability is the fact that Cummins® entities worldwide source these engines from Cummins India for their markets.

Unmatched Warranty

Cummins® 'K50 series' diesel engine generating sets are a truly cost effective solution to long term power need backed by industry best, 2 years | 5000 hrs warranty, for the entire generating set.

With superior experience in technology, design capability and commitment reliability and quality we offer an unmatched 5 years or 5000 hours (including above 2 years) warranty coverage on 5 critical components (5C) of the engine - Cylinder Head, Camshaft, Crankshaft, Cylinder Block, Connecting Rod against manufacturing defect

Cummins Advantage

Special features of Cummins® 'K50 series' engines like ESTC (Electrical Step Timing Control) injectors, BCS (Bank Cut off System), low temperature aftercooler, square combustion chamber, optimised turbocharging and precision heavy duty camshaft make these engines the ultimate in exceptional fuel efficiency across the operating range.

Single Source Power Assurance

Design, manufacture and testing of engine, alternator and other accessories is done by Cummins Group of companies for optimum performance and is backed by a countrywide product support network with a single source responsibility for the entire package.

Standard Scope

Engine: Cummins® 'K50 series' direct injection, water cooled engine, 16 cylinder, 4 stroke, rated at 1500 RPM has the following specifications:

- Cummins PT fuel pump
- Cummins heavy duty ESTC injectors
- Holset turbocharger, pulse tuned exhaust manifold, Stainless steel exhaust flexible connections
- Radiator & coolant inhibitor
- Plate type lube oil cooler
- Outboard after-coolers
- Full flow Spin-on type Lube oil & Fuel filters with Water Separators
- Dry type replaceable paper element air cleaner with restriction indicator
- Flywheel housing & flywheel to suit single bearing - flywheel housing & flywheel size SAE0/18
- Starting motor - Electric, battery charging alternator
- Cummins PowerCommand® microprocessor based genset controller
- First fill lube oil and coolant
- Diesel Oxidation Catalyst

Alternator: Stamford brushless alternator

- Separately excited, self-regulated -Class 'H' insulation
- Salient pole revolving field
- Single bearing
- PMG standard
- Space heater & RTD & BTD's only sensor (without scanner)

Accessories:

- Silencer suitably optimized to reduce noise
- Sturdy base rail
- 990 ltrs. free standing fuel tank
- 2 x 12V dry, uncharged batteries with connecting leads and terminals

Optional

Engine: Oil/Coolant heater, No cool

Control Panel: PC3.3, Power factor, Frequency, Current, Voltage - Remote HMI AMF control panel, Battery charger, Remote/Auto start panel, Auto/ Manual synchronizing panel, AudioNisual annunciation for faults, Auxiliary output relays and remote annunciators

**Control panel:
PowerCommand® PC 3.3**



The PowerCommand® control system is an integrated microprocessor based generator set control system providing voltage regulation, engine protection, alternator protection, operator interface and isochronous governing.

AmpSentry™ Includes integral AmpSentry™ protection, which provides a full range of alternator protection function which are matched to the alternator provided.

Power Management - Control function provides battery monitoring, testing and a smart starting control system.

Advanced Control Methodology - Three phase sensing, FET based full wave rectified voltage regulation and a PWM output for stable operation with all load types.

Communications Interface - Control comes standard with PCCNet and Modbus interface.

Service - InPower™ PC-based service tool available for detailed diagnostics, setup, data logging and fault simulation.

Reliable Design - For reliable operations in harsh environment.

Multi-language support

Independent of PC/ laptop for setting up

Operator panel features

Operator Panel Features - The operator panel, in addition to the alternator, displays the Utility/ AC Bus data.

Operator/ Display Functions

- 320 x 240 pixels graphic LED backlight LCD with bar graph for displaying electrical parameters
- Auto, manual, start, stop, fault reset and lamp test/panel lamp switches
- Alpha-numeric display with pushbuttons
- LED lamps indicating genset running, remote start, non auto, common shutdown, common warning, manual run mode, auto mode and stop

Paralleling Control Functions

- Digital frequency synchronization and voltage matching
- Isochronous kW and kvar load sharing controls
- Droop kW and kvar control
- Sync check
- Extended paralleling (Peak Shave/Base Load)
- Digital power transfer control (AMF) provides load transfer operation in open or closed transition or soft (ramping) transfer mode

Alternator Data

- Line-to-neutral & line-to-line AC Volts
- 3-phase AC current
- Frequency
- kW, kvar, power factor kVA (three phase and total)

Engine Data

- DC voltage
- Engine speed
- Lube oil pressure
- Coolant temperature/ low level
- Comprehensive FAE data (where applicable)

Other Data**Genset Model Data**

- Start attempts, starts, running hours, kW hours
- Load profile (operating hours at % load in 5% increments)
- Fault history
- Data logging and fault simulation (requires InPower)

Standard control functions**Digital Governing**

- Integrated digital electronic isochronous governor
- Temperature dynamic governing

Digital Voltage Regulation

- Integrated digital electronic voltage regulator
- 3-phase, 4-wire line-to-line sensing
- Configurable torque matching

AmpSentry, AC Protection

- AmpSentry protective relay
 - Over current and short circuit shutdown
 - Over current warning
 - Single and three phase fault regulation
- Over and under voltage shutdown
- Over and under frequency shutdown
- Overload warning with alarm contact
- Reverse power and reverse var shutdown
- Field overload

Engine protection

- Battery voltage monitoring, protection and testing
- Over speed shutdown
- Low oil pressure warning and shutdown
- High coolant temperature warning and shutdown
- Low coolant level warning or shutdown
- Low coolant temperature warning
- Fail to start (over crank) shutdown
- Fail to crank shutdown
- Cranking lockout
- Sensor failure indication
- Low fuel level warning

Control functions

- Time delay start and cool down
- Real time clock for fault and event time stamping
- Exerciser clock and time of day start/stop
- Data logging
- Cycle cranking
- Load shed/ dump as per configurable priority
- Configurable inputs and outputs (4)
- Remote emergency stop

Options

- Auxiliary output relays and remote annunciators

Technical Data

Technical Data

Generator set specification	
Model	C1800 D5P
Prime Power Rating kVA	1800
Output Voltage and Frequency	415 Volts, 50 Hz
Power Factor	0.8 (lag)
No. of phases	3 Phase
Engine specifications	
Make	Cummins
Model	KTA50- G29
No. of cylinders	16 'Vee'
Aspiration	Turbocharged-Aftercooled
Bore and Stroke	159 mm x 159 mm
Displacement	50.3 ltrs
Output - Prime	2101 bhp (1567 kWm)
Fuel consumption @ 75% load	281 ltr/hr
Fuel consumption @ 100% load	386 ltr/hr
Total wet weight (engine + radiator)	7967 kg
Length x Width x Height (engine)	2772 x 1684 x1800 mm
Compression Ratio	14.7:1
Piston Speed	7.95 m/s
Governor / Class	Electronic / A1
Lubricating oil system capacity	177 ltrs
Coolant capacity (engine + radiator)	530 ltrs
Combustion air intake @ 100% load (+/- 5%)	124.2 m3/min
Fan air flow across radiator	32191 ltrs/sec
Exhaust Temperature	457°C
Alternator specifications	
Make	Stamford LT
Frame size / Model No.	S7L1D-G4
Voltage Regulation	+ 0.5%
Insulation	Class H
Standard Enclosure	IP 23
Winding Pitch	2 / 3 Pitch
Stator Winding	Double layer concentric Dynamically
Rotor	balanced with grade 2.5
Total Harmonic Factor	<2% (50Hz)

Rating definitions

Prime Power (PRP):

Applicable for supplying power to varying electrical load for unlimited hours. Prime Power (PRP) is in accordance with ISO 8528. Ten percent overload capability is available in accordance with ISO 3046.

- Fuel consumption data is based on diesel having specific gravity of 0.85 and conforming to IS:1460
- Fuel consumption tolerance is +5%

Typical Open Genset Dimensions

Genset Model	Rating (kVA)	Length (mm)	Width (mm)	Height (mm)	Wet Weight## (kg)	Standard Fuel Tank Capacity - External
C1800 D5 P	1800 kVA	5870	2670	3335	13250	990

Approximate Weight

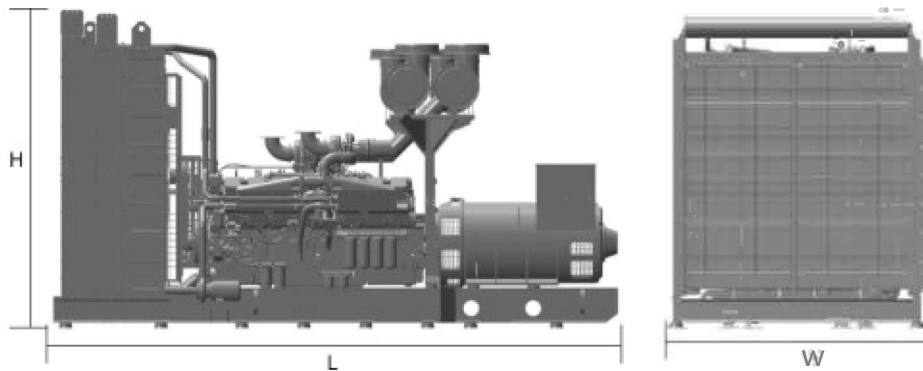

* Approximate Weight

** Total tank capacity including dead stock

Authorised Representative



Get in Touch with Us

Plot N0-1, Sector-34, E.H.T.P,
Gurugram-122001, Haryana
Info@sudhirpower.com
+91-124-4168000

<https://www.facebook.com/sudhirpowerofficial/>

<https://www.linkedin.com/company/sudhir-power-limited/>

https://www.instagram.com/sudhir_power/

https://x.com/sudhir_powers

<https://www.youtube.com/@sudhirpowerlimitedofficial>

